



ISO 9001

SERIES 98



ECONOMICAL
COMPACT (WAFER TYPE) BALL VALVES
FULL BORE - DN 15 TO DN 100
DIN PN 10/16 & ANSI CLASS 150

DESIGN ADVANTAGES

- DIN 3337/ISO 5211 MOUNTING PAD
- SELF ADJUSTING STEM SEAL AUTOMATICALLY ADJUSTS SEAL TO COMPENSATE FOR WEAR, TEMPERATURE AND PRESSURE FLUCTUATIONS.
- COMPACT SPACE SAVING DESIGN, LOW COST CONSTRUCTION.
- BLOW-OUT PROOF STEM
- WIDE RANGE OF SEAT AND SEAL MATERIAL AVAILABLE

SPECIFICATIONS

Size Range and
 Construction : One-Piece Body, Full Bore
 DN15 to DN 100 Investment Cast
 DN125 to DN 200 Sand Cast

Body : DIN 1.4408 / 1.0619
 Ball and Stem : 316 S.S.
 Seat : Reinforced Teflon
 Rating : PN 10/16, ANSI 150
 Temperature : -40° F ~ 385° F (PTFE)

APPLICATIONS :

Chemical products, Water, Gas, Solvent, Food Industry and Others.

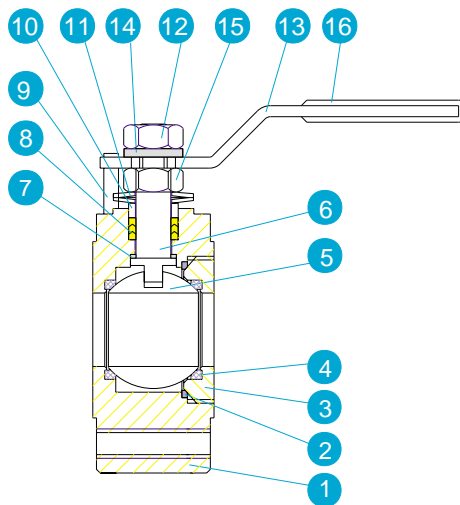

DN15~DN25

MATERIALS LIST

NO.	PART NAME	MATERIAL	NO.
1	Body	A351-CF8M A216-WCB	1
2	Gasket	PTFE	1
3	Ring Nut	A351-CF8M A216-WCB	1
4	Ball Seat	PTFE	2
5	Ball	A351-CF8M	1
6	Stem	AISI-316 AISI-304	1
7	Stem Seal	PTFE	1
8	Stem Packing	PTFE	1
9	Stop	AISI-304	1
10	Ring	AISI-304	1
11	Belleville Washer	AISI-301	2
12	Nut	AISI-304	1
13	Handle	AISI-304	1
14	Spring Washer	AISI-304	1
15	Nut	AISI-304	1
16	Handle Sleeve	Vinyl	1

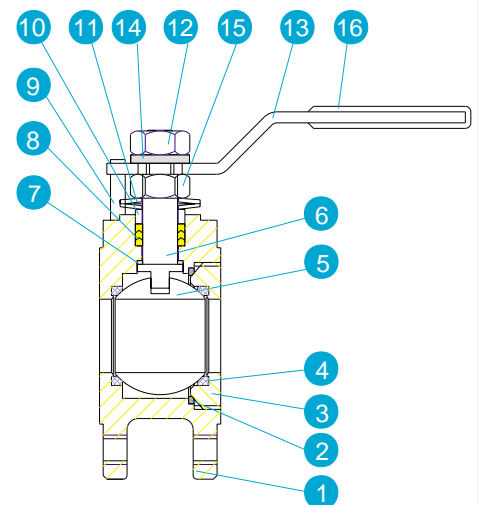

DN32~DN100

OPTION

Mounting Brackets and Couplers

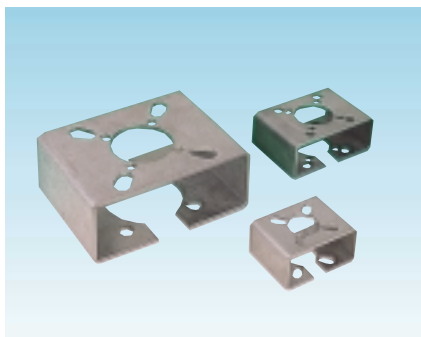

Pressure Vs. Temperature Chart

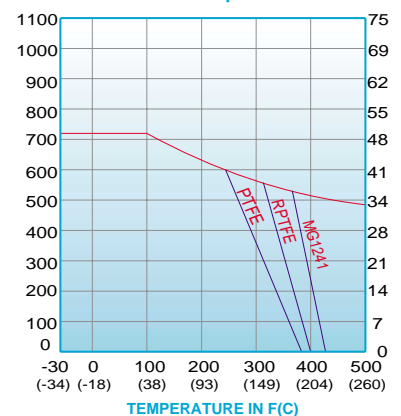

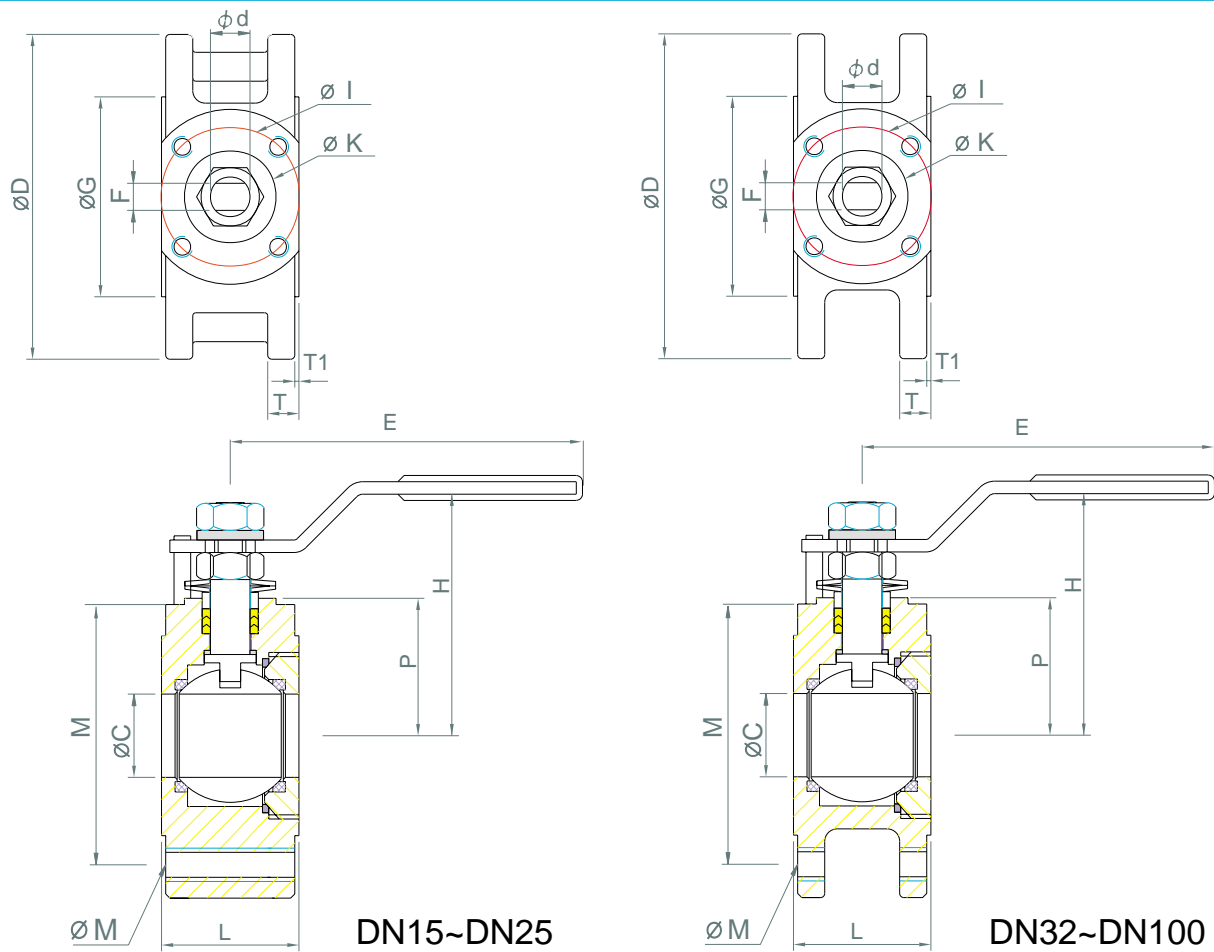

DIMENSION (mm)

DN	ϕC	ϕD	ϕd	E	F	ϕG	H	ϕI	ϕK	L	ϕM	M	T	T1	P3	ISO5211
15	16.0	90	10	116	6.5	45	57	36	25	35	M12	65	7.1	2	32	F03
20	20.0	100	10	116	6.5	58	64	36	25	38	M12	75	7.5	2	38	F03
25	25.0	110	10	165	6.5	65	68	36	25	44	M12	85	8.5	3	42	F03
32	32.0	130	16	165	8.5	78	85	42	32	54	M16	100	17	3	50	F04
40	38.0	150	16	193	8.5	88	89	50	35	62	M16	110	17	4	54	F05
50	50.0	150	16	193	8.5	102	98	50	35	80	M16	125	19	4	62	F05
65	64.0	178	20	235	12	122	129	70	53	101	M16	145	19	4	82	F07
80	76.0	190	20	235	12	138	138	70	55	118	M16	160	21	4	91	F07
100	96.0	220	24	329	16	158	164	102	55	150	M16	180	24	4	107	F10

• Size: DN125 to DN200 Please Consult Factory

BREAK AWAY TORQUE & Cv VALVES HOW TO ORDER

VALVE SIZE		FLOW COEFFICIENT		LIMITING STEM INPUT TORQUE	
M.M	INCH	Cv	Kv	LBFIN IN	NM
15	1/2"	7	6	117	13.2
20	3/4"	10	8.7		
25	1"	30	26		
32	1 1/4"	46	57	430	48.6
40	1 1/2"	89	77		
50	2"	130	112.5		
80	3"	350	303	3400	385
100	4"	720	623		
Cv FLOW-US GPM (PRESSURE-PSI)		Kv FLOW-M/MR (PRESSURE-BAR)			

VALVE SERIES		VALVE SIZE	BODY MATERIAL	SEAT MATERIAL
98-10	PN 10/16	03 DN 15	S 1.4408	P PTFE
98-20	PN 25/40	04 DN 20	W 1.0619	R R-PTFE
98-30	ANSI 150	05 DN 25	*Other materials please consult factory	S 50/50 S.S.
		06 DN 32		filled PTFE
		07 DN 40		C Carbon filled
		08 DN 50		PTFE
		09 DN 65		D Delrin
		10 DN 80		M MG1241
		11 DN 100		U UHMWPE



MARS VALVE CO.,LTD.
 7F-6,NO.200,SEC.4,WEN-SHIN ROAD
 TAICHUNG,TAIWAN,R.O.C.
 TEL:++886-4-297 3808
 FAX:++886-4-297 3608
 E-MAIL:mars@marsvalve.com.tw
<http://www.marsvalve.com.tw/>

Distributor: